

# GTMR 336 B

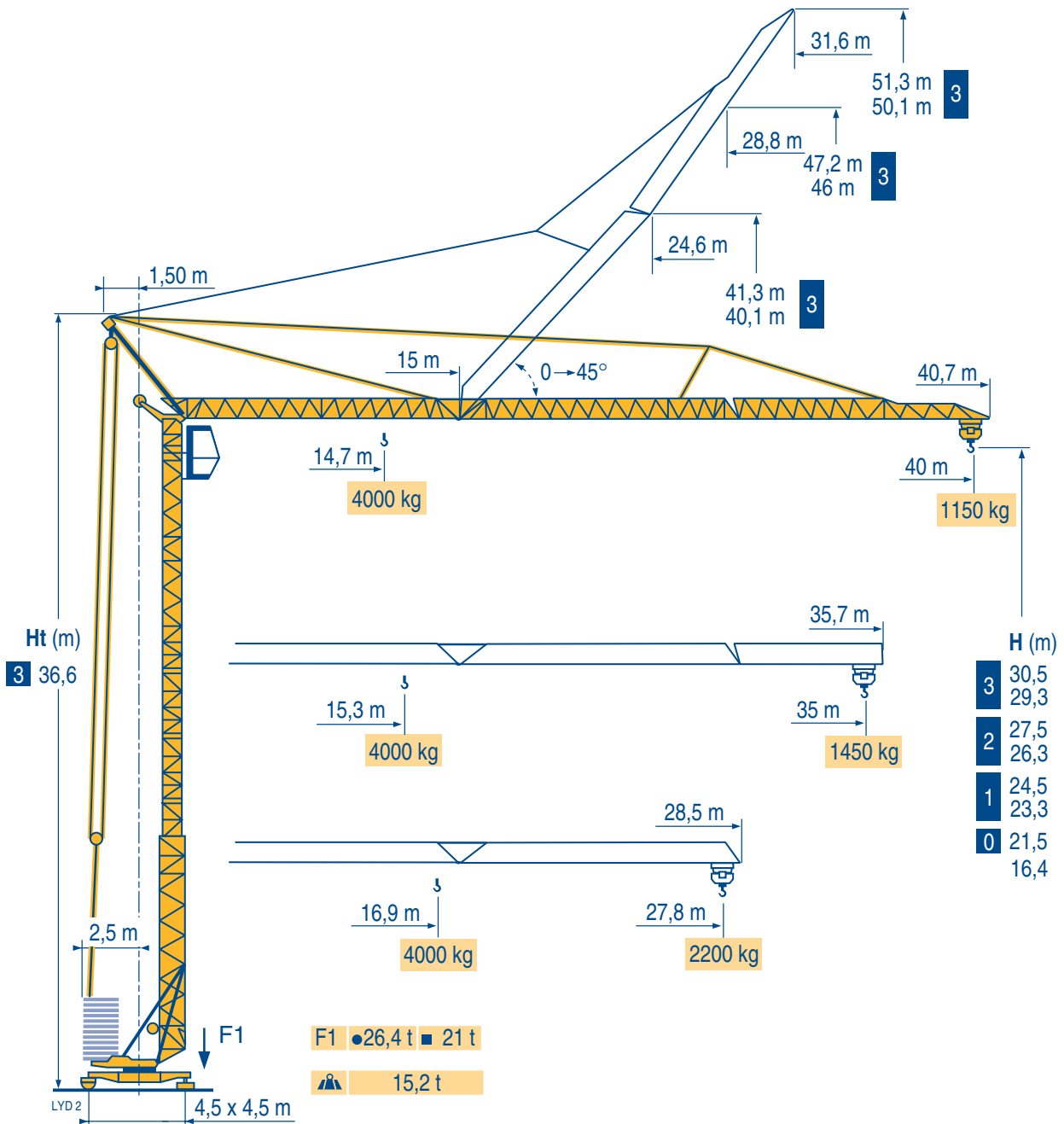

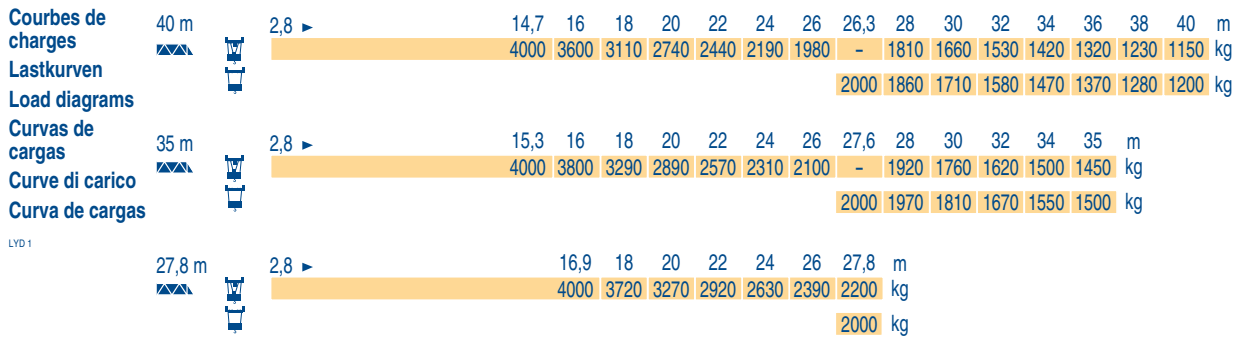

**F**  
**Flèche relevée**  
**Ausleger in Steilstellung**  
**Luffing jib**  
**Flecha izada**  
**Braccio impennato**  
**Lança inclinada**

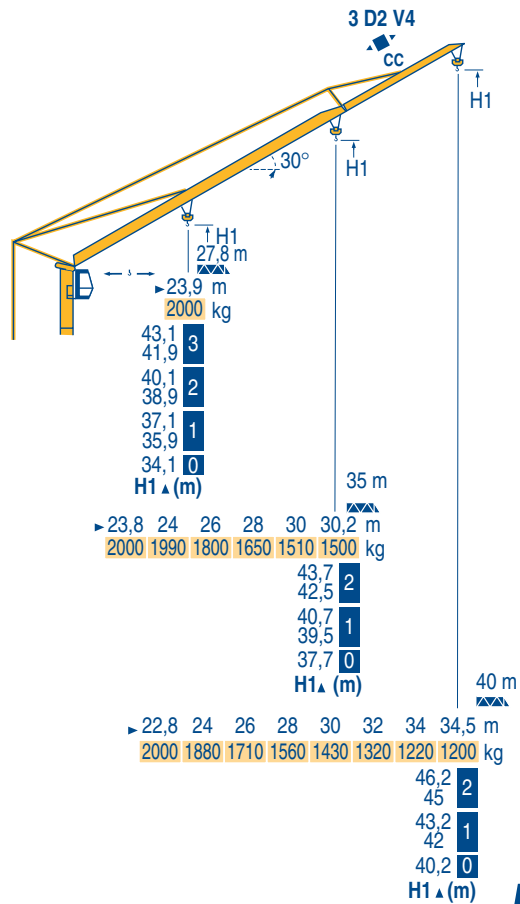
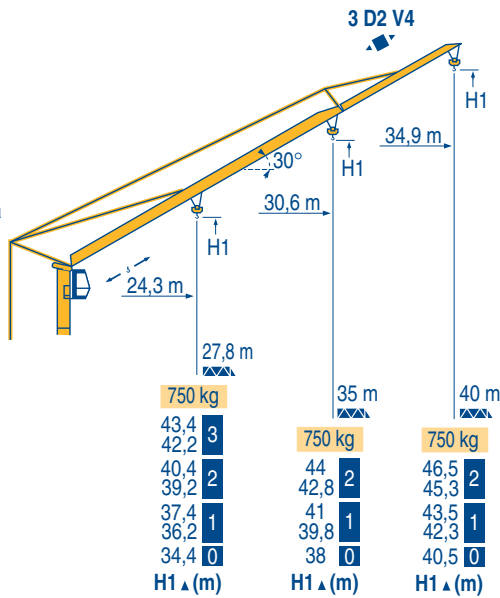

**GTMR 336 B**



<b>F</b> Chariot distributeur Chariot distributeur et courbes de charges Réactions en service Réactions hors service A vide sans lest (ni train de transport) avec flèche et hauteur maximum.	<b>D</b> Verfahrbare Laufkatze Verfahrbare Laufkatze und Lastkurven Reaktionskräfte in Betrieb Reaktionskräfte außer Betrieb Ohne Last, Ballast (und Transportachse), mit Maximalausleger und Maximalhöhe.	<b>GB</b> Traversing trolley Traversing trolley and load diagrams Reactions in service Reactions out of service Without load, ballast (or transport axes), with maximum jib and maximum height.	<b>E</b> Carro distribuidor Carro distribuidor y curvas de cargas Reacciones en servicio Reacciones fuera de servicio Sin carga, sin lastre, (ni tren de transporte), flecha y altura máxima.	<b>I</b> Carrellino distributore Carrellino distributore e curve di carico Reazioni in servizio Reazioni fuori servizio A vuoto, senza zavorra (ne assali di trasporto) con braccio massimo e altezza massima.	<b>P</b> Carro distribuidor Carro distribuidor e curva de cargas Reações em serviço Reações fora de serviço Sem carga (nem trem de transporte)- sem lastro com lança e altura máximas.
--	---	--	--	---	---

Mécanismes  
Antriebe  
Mechanisms  
Mecanismos  
Meccanismi  
Mecanismos

LVD 1

			Lifting			Lifting			ch - PS hp	kW
			Person	Person	Person	Person	Person	Person		
▲ ▼	20 TDPC 10	m/min	8	25	50	4	12,5	25	20	15
		kg	2000	2000	1300	4000	4000	2600		
▲ ▼	20 LVF 10	m/min	5	25	50	2,5	12,5	25	20	15
		kg	2000	2000	1300	4000	4000	2600		
◀ ▶	3 D2 V4	m/min	22 - 44						4	3
⦿	RCV 32	tr/min U/min rpm	0 → 0,8						4	3
⦿ ⦿ R ≥ 8 m	TVD 122	m/min	25						2 x 2	2 x 1,5
	TB 122	m/min	25						2 x 2	2 x 1,5
CEI 38		IEC 38	kVA			Headset				
400 V (+6% -10%) 50 Hz			25 kVA			2000/14				

Montage  
Montage  
Erection  
Montaje  
Montaggio  
Montagem

LVD 1

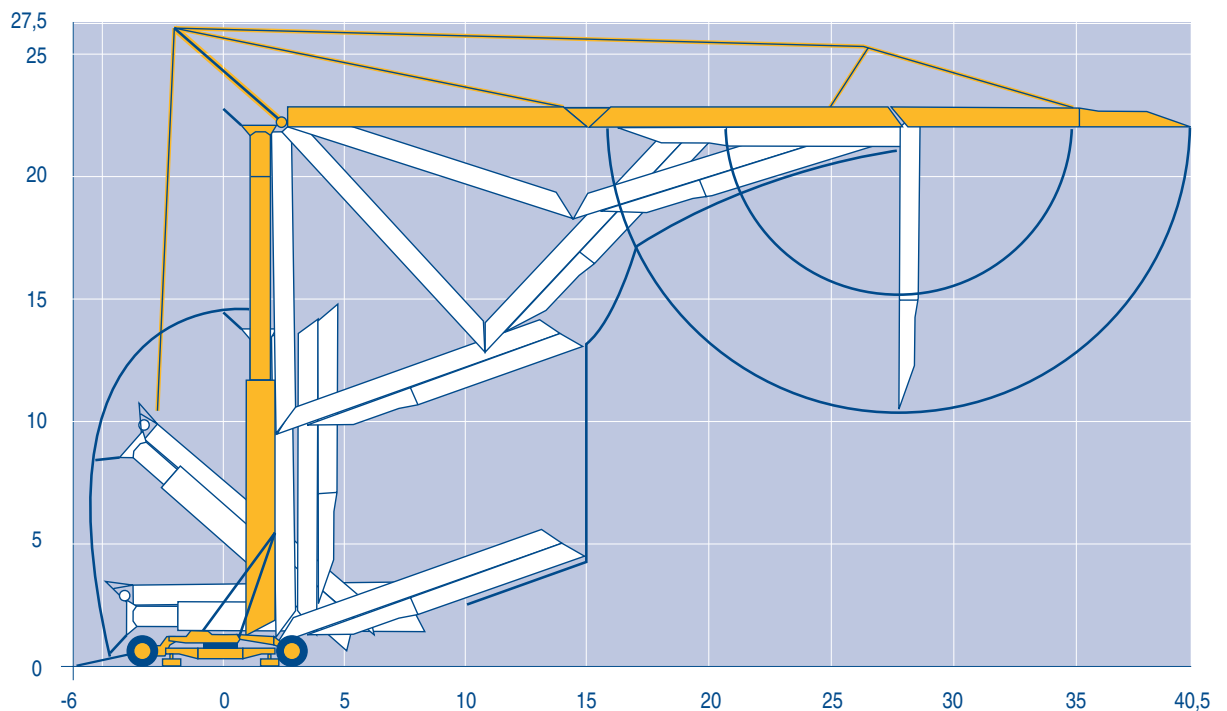

GTMR 336 B

POTAIN®



F	D	GB	E	I	P
Levage	Heben	Hoisting	Elevación	Sollevamento	Elevação
Distribution	Katzfahren	Trolleying	Distribución	Distribuzione	Distribuição
Orientation	Schwenken	Slewing	Orientación	Rotazione	Rotação
Translation	Kranfahren	Travelling	Traslación	Traslazione	Translação
Conforme aux directives CEE sur le niveau acoustique	Gemäss EWG-Richtlinien für den Schall-Leistungspegel	In compliance with the EEC Instructions on noise level	Conforme con las directivas CEE sobre el nivel acustico	Conforme alle direttive CEE sul livello acustico	Conforme as directivas CEE sobre o nível acústico

Transport  
Transport  
Transport  
Transporte  
Trasporto  
Transporte

LYD 1

15A/25A

DJ126M/S215M

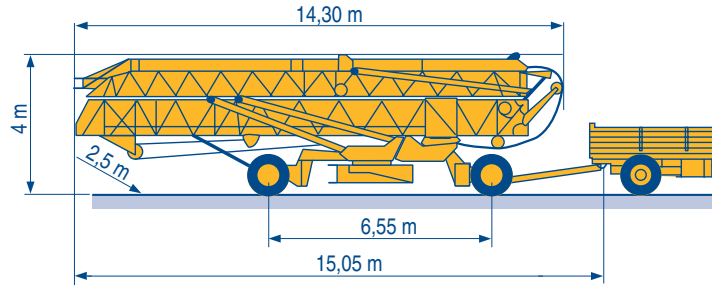

S4/S215M

S5B/J215M

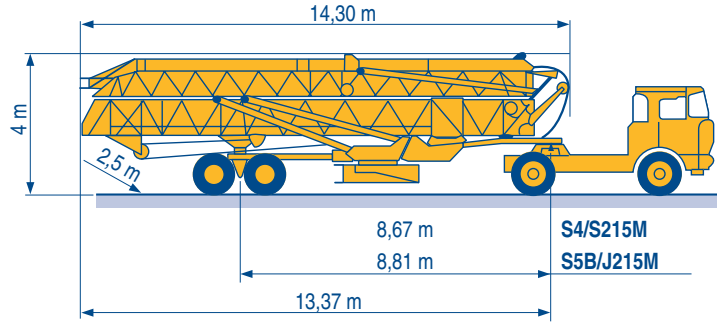

Document commercial non contractuel. Pour toute information technique se référer à la notice correspondante

Unverbindliches Vertriebsdokument. Für technische Informationen, siehe die entsprechenden Anweisungen.

This commercial document is not legally binding. For any technical information, please refer to the corresponding instructions.

Documento commercial non contractuel. Para cualquier información técnica, ver la noticia correspondiente.

Documento commerciale non vincolante. Per tutte le informazioni tecniche fare riferimento al catalogo istruzioni

Documento comercial não contratual. Para qualquer informação técnica complementar consultar as respectivas instruções

**Manitowoc**  
Crane CARE

**POTAIN**   
Manitowoc Crane Group



18, rue de Charbonnières - B.P.173  
69132 ECULLY Cedex - France

Tél. : (33) 4 72 18 20 20  
Fax. : (33) 4 72 18 20 00  
www.manitowoccrane.com www.potain.com

**BÖNEMANN**   
GMSH  
POTAIN 

**Americas**  
Tel: +1 920 683 6322  
Tel: +1 717 597 8121

**Europe - Middle East - Africa**  
Tel : +(33) 4 72 81 50 00  
Tel : +(44) 191 565 6281

**Asia - Pacific**  
Tel: +(65) 6861 7133  
Fax: +(65) 6862 4142

www.manitowoccrane.com

**GTMR 336 B**

Réf. 2003 48 LYD 2

Copyright.Reproduction interdite © POTAIN 2003

Réalisation HeadLines